



Internal Combustion Engine Counterbalance Truck

H35 – H50

Capacity 3.5 - 5.0 t | Series 1204

Robust all-rounder

- Hydrostatic drive, double pedal control and Linde Load Control for efficient load handling
- Robust design and maintenance-free components guarantee high vehicle availability and low operating costs
- Asymmetric slim mast profiles, narrow A-pillar, lowered front plate and large roof panel for excellent visibility
- Wireless data transmission for smooth integration in software systems, e.g. for fleet management
- The vehicle's low center of gravity and intelligent assistance systems reduce the risk of tipping and accidents

STANDARD AND OPTIONAL EQUIPMENT

H35 - H50		H35 D - H50 D	H35 T - H50 T	H35 CNG - H50 CNG
Operator Compartment	Ergonomic and save truck access due to a low entry step and handle bar at a-pillar and bonnet	●	●	●
	Innovative decoupling concept for lowest human vibrations	●	●	●
	Tilt adjustable steering column	●	●	●
	Overhead guard comfort for max. head clearance	●	●	●
	Operator's seat - mechanical quick weight adjustment	●	●	●
	Various seating options such as heating, air suspension, active seat ventilation, longitudinal suspension	○	○	○
	Operators seat - Swiveling seat	○	○	○
	Coloured 3.5" LED display with steering angle indicator and tilt angle indicator	●	●	●
	Coloured 7" LED multifunction display integrates additional functions e.g. cameras and Linde Safety Pilot	○	○	○
	Top screen armored glass	○	○	○
	Alloy doors with openable window	○	○	○
	Din A4 illuminated clipboard	○	○	○
	Warm water heater incl. defog function/air conditioning	○	○	○
Radio, DAB+, MP3 Player incl. bluetooth hands-free equipment	○	○	○	
Driving and Lifting	Linde Hydrostatic Drive - for high productivity and low fuel consumption	●	●	●
	Powerful 4-cylinder Diesel industrial engine from Doosan stage V certified (EU version)	●	—	—
	Powerful 4-cylinder CNG industrial engine from Doosan stage V certified (EU version)	—	—	●
	Powerful 4-cylinder LPG industrial engine from Doosan stage V certified (EU version)	—	●	—
	Ergonomic LPG twin bottle change with low handling point	—	●	●
	LPG tank including fill level indicator in the display	—	○	—
	Engine air filter including safety elements	●	●	●
	Linde Engine Protection System (LEPS) - warning, speed reduction under critical engine conditions	●	●	●
	Hydraulic parking brake	●	●	●
	Oversized, variable displacement pump for lifting function - for low fuel consumption, low noise level and emissions	●	●	●
	Hydraulic filter concept - realizing 6000 hour hydraulic-oil change interval	●	●	●
	Power setting efficiency, economy, performance	●	●	●
	Super Elastic (SE) Tyres	●	●	●
	Closed Shoulder Tyres CS 20	○	○	○
	Pneumatic Tyres	○	○	○
Antistatic, non marking Tyres	○	○	○	
Anti-spray mudflaps front and rear	○	○	○	
Mast	Top mounted tilting cylinders - including maintenance free bearings	●	●	●
	Best visibility through asymmetric, nested mast profiles on standard, duplex, triplex masts	●	●	●
	Electronic damped tilt stop	●	●	●
	Hydraulic accumulator for high driving comfort and less wear	○	○	○
Attachments/ Forks	Reinforced Linde forks - easy ajustable and long life time	○	○	○
	Integrated sideshift with full lift capacity and roller guided	○	○	○
	Integrated fork positioner "View" for high residual capacities and optimized visibility	○	○	○
	Street sweeper preparation	○	○	○
Safety	Linde Curve Assist - automatic drive speed reduction when cornering	●	●	●
	Electrical seat belt monitoring - visual and acoustic feedback	●	●	●
	Linde Load Assist - increased safety at high lift heights	●	●	●
	BlueSpot and TruckSpot - optical warning signal for pedestrians and drivers	○	○	○
	Load weight indicator	○	○	○
	Linde Safety Pilot - load-dependent travel and lifting speed intervention plus additional functions	○	○	○
	Linde Safety Guard - truck to truck warning and truck to pedestrian warning	○	○	○
	Speed limitations (via switch, indoor-outdoor, load depending)	○	○	○
Restraint systems (different options)	○	○	○	
Digitalisation	Data Transmission Online	●	●	●
	Data Transmission Wifi	○	○	○
	Linde connect:desk - local fleet management with different functional modules	○	○	○
	Linde connect:cloud - fleet management as a service (hosted version)	○	○	○
	Pre-Operation-Check - individualizable daily check protocol for operational readiness	○	○	○
	Truck Call App - coordination of transport orders	○	○	○
Operation/ Load Handling	Double pedal control - Stepless acceleration and fast reversing	●	●	●
	Single pedal control - Stepless acceleration	○	○	○
	Linde Load Control - central levers fully integrated in the armrest for precise control of all hydraulic functions	●	●	●
	Individual Lever System	○	○	○

● Standard equipment ○ Optional equipment — Not available

LOAD CAPACITY

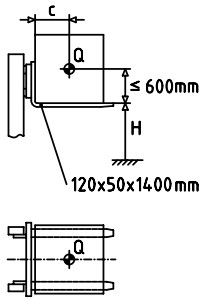

H (mm)	Q (kg)			
7000	2400	2200	2030	1880
6900	2520	2310	2130	1980
6800	2640	2420	2230	2070
6700	2760	2530	2340	2170
6600	2880	2640	2440	2260
6500	3010	2760	2540	2360
6400	3130	2870	2650	2460
6300	3250	2980	2750	2550
6200	3370	3090	2850	2650
≤ 6100	3500	3200	2960	2750
c (mm)	400 - 600	700	800	900

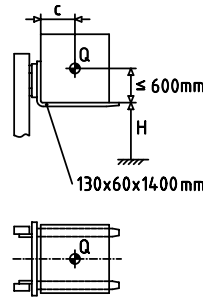

H40 / 600

H (mm)	Q (kg)			
7000	2400	2200	2030	1880
6800	2660	2440	2250	2090
6700	2800	2560	2370	2200
6600	2930	2690	2480	2300
6500	3060	2810	2590	2410
6400	3200	2930	2710	2510
6300	3330	3050	2820	2620
6200	3460	3180	2930	2720
6100	3600	3300	3050	2830
6000	3730	3420	3160	2930
5900	3860	3540	3270	3040
≤ 5800	4000	3660	3380	3140
c (mm)	400 - 600	700	800	900

H45 / 600

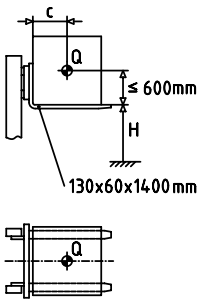

H (mm)	Q (kg)			
7000	2500	2290	2120	1970
6800	2830	2600	2400	2240
6700	3000	2750	2550	2370
6600	3160	2910	2690	2500
6500	3330	3060	2830	2630
6400	3500	3210	2970	2760
6300	3660	3360	3110	2900
6200	3830	3520	3250	3030
6100	4000	3670	3400	3160
6000	4160	3820	3540	3290
5900	4330	3980	3680	3420
≤ 5800	4500	4130	3820	3550
c (mm)	400 - 600	700	800	900

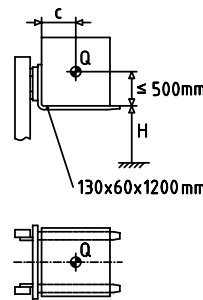

H50 / 500

H (mm)	Q (kg)			
7000	2800	2550	2340	2170
6800	3160	2880	2650	2450
6700	3350	3050	2800	2590
6600	3530	3220	2960	2730
6500	3710	3380	3110	2880
6400	3900	3550	3260	3020
6300	4080	3720	3420	3160
6200	4260	3890	3570	3300
6100	4450	4050	3720	3450
6000	4630	4220	3880	3590
5900	4810	4390	4030	3730
≤ 5800	5000	4550	4190	3870
c (mm)	400 - 500	600	700	800

H50 / 600

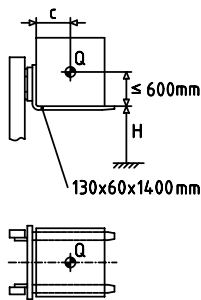

H (mm)	Q (kg)			
7000	2800	2570	2380	2210
6800	3160	2910	2690	2500
6700	3350	3070	2840	2640
6600	3530	3240	3000	2790
6500	3710	3410	3150	2930
6400	3900	3580	3310	3080
6300	4080	3750	3470	3220
6200	4260	3920	3620	3370
6100	4450	4080	3780	3510
6000	4630	4250	3930	3660
5900	4810	4420	4090	3800
≤ 5800	5000	4590	4250	3950
c (mm)	400 - 600	700	800	900

H = Lifting height, c = Load centre, Q = Load capacity
Load capacity for standard mast and fork carriage

TECHNICAL DATA (According to VDI 2198)

	Characteristics		LINDE	LINDE	LINDE	LINDE	LINDE		
			H35 / 600 D	H40 / 600 D	H45 / 600 D	H50 / 500 D	H50 / 600 D		
Characteristics	1.1	Manufacturer	LINDE	LINDE	LINDE	LINDE	LINDE		
	1.2	Manufacturer's type designation	H35 / 600 D	H40 / 600 D	H45 / 600 D	H50 / 500 D	H50 / 600 D		
	1.3	Power unit	Diesel	Diesel	Diesel	Diesel	Diesel		
	1.4	Operation	Seat	Seat	Seat	Seat	Seat		
	1.5	Load capacity/Load	Q (t)	3.5	4.0	4.5	4.999	4.999	
	1.6	Load centre distance	c (mm)	600	600	600	500	600	
	1.8	Axle centre to fork face	x (mm)	500	510	535	535	535	
	1.9	Wheelbase	y (mm)	2030	2030	2070	2070	2110	
	Weights	2.1	Service weight	kg	5722	6188	6706	6682	7087
2.2		Axle load with load, front/rear	kg	8167/1055	9020/1168	9972/1234	10464/1218	10767/1319	
2.3		Axle load without load, front/rear	kg	2770/2952	2833/3355	3005/3701	2965/3717	3079/4008	
Wheels/Tyres	3.1	Tyres rubber, SE, pneumatic, polyurethane	SE	SE	SE	SE	SE		
	3.2	Tyre size, front	250/70-15 (250-15)	250/70-15 (250-15)	315/70-15 (300-15)	315/70-15 (300-15)	315/70-15 (300-15)		
	3.3	Tyre size, rear	250/70-15 (250-15)	250/70-15 (250-15)	250/70-15 (250-15)	250/70-15 (250-15)	250/70-15 (250-15)		
	3.5	Wheels, number front/rear (x = driven)	2x/2	2x/2	2x/2	2x/2	2x/2		
	3.6	Track width, front	b10 (mm)	1221	1221	1190	1190	1190	
	3.7	Track width, rear	b11 (mm)	1123	1123	1123	1123	1123	
	Dimensions	4.1	Mast/fork carriage tilt, forward/backward	a/b (°)	5.0/8.0 ¹⁾	5.0/8.0 ¹⁾	5.0/8.0 ¹⁾	5.0/8.0 ¹⁾	5.0/8.0 ¹⁾
4.2		Height of mast, lowered	h1 (mm)	2425 ²⁾	2425 ²⁾	2474 ²⁾	2474 ²⁾	2474 ²⁾	
4.3		Free lift	h2 (mm)	150	150	150	150	150	
4.4		Lift	h3 (mm)	3100	3100	3100	2900	2900	
4.5		Height of mast, extended	h4 (mm)	4023	4023	4023	3923	3923	
4.7		Height of overhead guard (cabin)	h6 (mm)	2414 ³⁾	2414 ³⁾	2456	2456	2455	
4.8		Seat height relating to SIP/stand height	h7 (mm)	1298	1298	1341	1341	1341	
4.12		Towing coupling height	h10 (mm)	661	660	675	675	674	
4.19		Overall length	l1 (mm)	4251	4261	4326	4126	4366	
4.20		Length to fork face	l2 (mm)	3051	3061	3126	3126	3166	
4.21		Overall width	b1/b2 (mm)	1446/1410	1446/1410	1448/1410	1448/1410	1448/1410	
4.22		Fork dimensions DIN ISO 2331	s/e/l (mm)	50 × 120 × 1 200	60 × 130 × 1200	60 × 130 × 1200	60 × 130 × 1000	60 × 130 × 1200	
4.23		Fork carriage to ISO 2328, class/type A, B		3 A	3 A	3 A	3 A	3 A	
4.24		Width of fork carriage	b3 (mm)	1350	1350	1350	1350	1350	
4.31		Ground clearance, below mast	m1 (mm)	158	156	203	202	202	
4.32		Ground clearance, centre of wheelbase	m2 (mm)	207	207	250	250	250	
4.34.1		Aisle width for pallets 1000 × 1200 crossways	Ast (mm)	4443 ⁴⁾	4453 ⁴⁾	4520 ⁴⁾	4520 ⁴⁾	4563 ⁴⁾	
4.34.2		Aisle width with pallet 800 × 1200 along forks	Ast (mm)	4643 ⁴⁾	4653 ⁴⁾	4720 ⁴⁾	4720 ⁴⁾	4763 ⁴⁾	
4.35		Turning radius	Wa (mm)	2743	2743	2785	2785	2828	
4.36	Minimum pivoting point distance	b13 (mm)	808	808	823	823	838		
Performance	5.1	Travel speed, with/without load	km/h	21/21	21/21	24/24	24/24	24/24	
	5.1.1	Travel speed, with/without load, backwards	km/h	21/21	21/21	24/24	24/24	24/24	
	5.2	Lifting speed, with/without load	m/s	0.53/0.57	0.53/0.57	0.53/0.57	0.5/0.53	0.5/0.53	
	5.3	Lowering speed, with/without load	m/s	0.56/0.53	0.56/0.53	0.56/0.53	0.54/0.51	0.54/0.51	
	5.5	Tractive force, with/without load	N	29171/21735	28972/22413	25072/23786	24951/23753	24903/24209	
	5.7	Climbing ability, with/without load	%	34.1/29.8	30.2/28.2	23.4/27.5	22.2/27.5	21.5/26.7	
	5.9	Acceleration time, with/without load	s	5.4/4.9	5.5/4.9	5.6/5.0	5.7/5.0	5.8/5.1	
	5.10	Service brake		hydrostatic	hydrostatic	hydrostatic	hydrostatic	hydrostatic	
	Drive	7.1	Engine manufacturer/type		Doosan D24	Doosan D24	Doosan D24	Doosan D24	Doosan D24
		7.2	Engine performance according to DIN ISO 1585	kW	55	55	55	55	55
7.3		Rated speed	1/min	2300	2300	2300	2300	2300	
7.4		Number of cylinders/displacement	-/cm ³	4/2393	4/2393	4/2393	4/2393	4/2393	
7.5 a b		Fuel consumption according to DIN EN 16796	t/h kg/h m ³ /h	3.7 - -	3.8 - -	4.0 - -	4.2 - -	4.3 - -	
7.5.1		CO2 equivalent according to EN 16796	kg/h	11.8	12.1	12.7	13.3	13.7	
7.6		Turnover output according to VDI 2198	t/h	291.0	334.0	373.0	399.0	387.0	
7.7 a b		Turnover efficiency according to VDI 2198	t/l t/kg t/m ³	48.5 - -	54.8 - -	59.2 - -	60.5 - -	58.6 - -	

1) Lift height and equipment can alter rear mast tilt angle
2) With 150 mm free lift on standard mast
3) +2 mm with KCU

4) Including a 200 mm (min.) operating aisle clearance
5) +10 mm with KCU
6) CNG H - Gas = GR; CNG L - Gas = G25

LINDE	LINDE	LINDE	LINDE	LINDE	LINDE	LINDE	LINDE
H35/600 T	H40/600 T	H45/600 T	H50/500 T	H50/600 T	H50/600 D-Container	H50/600 D Beverage	H50/600 CNG
LPG	LPG	LPG	LPG	LPG	Diesel	Diesel	CNG
Seat	Seat	Seat	Seat	Seat	Seat	Seat	Seat
3.5	4.0	4.5	4.999	4.999	4.999	4.999	4.999
600	600	600	500	600	600	600	600
500	510	535	535	535	510	535	535
2030	2030	2070	2070	2110	2110	2110	2110
5843	6309	6827	6803	7208	6991	7536	7266
8161/1182	9014/1295	9968/1359	10460/1343	10765/1442	10599/1391	11047/1488	10768/1497
2764/3079	2827/3482	3001/3826	2961/3842	3077/4131	2970/4021	3359/4177	3080/4186
SE	SE	SE	SE	SE	SE	SE	SE
250/70-15 (250-15)	250/70-15 (250-15)	315/70-15 (300-15)	315/70-15 (300-15)	315/70-15 (300-15)	355/45-15 (28x12.5-15)	315/70-15 (300-15)	315/70-15 (300-15)
250/70-15 (250-15)	250/70-15 (250-15)	250/70-15 (250-15)	250/70-15 (250-15)	250/70-15 (250-15)	250/70-15 (250-15)	250/70-15 (250-15)	250/70-15 (250-15)
2x/2	2x/2	2x/2	2x/2	2x/2	2x/2	2x/2	2x/2
1221	1221	1190	1190	1190	1190	1190	1190
1123	1123	1123	1123	1123	1123	1123	1123
5.0/8.0 ¹⁾	5.0/8.0 ¹⁾	5.0/8.0 ¹⁾	5.0/8.0 ¹⁾	5.0/8.0 ¹⁾	5.0/8.0 ¹⁾	5.0/8.0 ¹⁾	5.0/8.0 ¹⁾
2425 ²⁾	2425 ²⁾	2474 ²⁾	2474 ²⁾	2474 ²⁾	2208 ²⁾	2874 ²⁾	2474 ²⁾
150	150	150	150	150	150	150	150
3100	3100	3100	2900	2900	2500	4100	2900
4023	4023	4023	3923	3923	3505	4323	3923
2414 ³⁾	2414 ³⁾	2456	2456	2456	2224 ⁵⁾	2855	2456
1298	1298	1341	1341	1341	1289	1741	1341
661	660	675	675	674	688	674	674
4251	4261	4326	4126	4366	4341	4366	4366
3051	3061	3126	3126	3166	3141	3166	3166
1446/1410	1446/1410	1448/1410	1448/1410	1448/1410	1490/1410	1448/1410	1448/1410
50 × 120 × 1200	60 × 130 × 1200	60 × 130 × 1200	60 × 130 × 1000	60 × 130 × 1.200	60 × 130 × 1200	60 × 130 × 1200	60 × 130 × 1200
3 A	3 A	3 A	3 A	3 A	3 A	3 A	3 A
1350	1350	1350	1350	1350	1350	1350	1350
158	156	203	202	202	142	202	202
207	207	250	250	250	216	250	250
4443 ⁴⁾	4453 ⁴⁾	4520 ⁴⁾	4520 ⁴⁾	4563 ⁴⁾	4538 ⁴⁾	4563 ⁴⁾	4563 ⁴⁾
4643 ⁴⁾	4653 ⁴⁾	4720 ⁴⁾	4720 ⁴⁾	4763 ⁴⁾	4738 ⁴⁾	4763 ⁴⁾	4763 ⁴⁾
2743	2743	2785	2785	2828	2828	2828	2828
808	808	823	823	838	838	838	838
21/21	21/21	24/24	24/24	24/24	20/20	24/24	24/24
21/21	21/21	24/24	24/24	24/24	20/20	24/24	24/24
0.53/0.57	0.53/0.57	0.53/0.57	0.5/0.53	0.5/0.53	0.5/0.53	0.5/0.53	0.5/0.53
0.56/0.53	0.56/0.53	0.56/0.53	0.54/0.51	0.54/0.51	0.54/0.51	0.54/0.51	0.54/0.51
29147/21735	28948/22361	25049/23753	24951/23753	24880/24195	29546/23360	24815/25796	24868/24216
33.6/29.0	29.8/27.5	23.1/26.9	22.0/26.9	21.3/26.2	25.9/26.6	20.6/26.7	21.1/25.9
5.1/4.6	5.3/4.7	5.5/4.9	5.6/4.9	5.7/5.0	5.8/5.1	6.0/5.2	5.8/5.1
hydrostatic	hydrostatic	hydrostatic	hydrostatic	hydrostatic	hydrostatic	hydrostatic	hydrostatic
Doosan P34	Doosan P34	Doosan P34	Doosan P34	Doosan P34	Doosan D24	Doosan D24	Doosan P34
55	55	55	55	55	55	55	50 (H); 48 (L) ⁶⁾
2300	2300	2300	2300	2300	2300	2300	2300
4/3409	4/3409	4/3409	4/3409	4/3409	4/2393	4/2393	4/3.409
- 3.7 -	- 3.8 -	- 3.9 -	- 4.1 -	- 4.2 -	- 4.3 -	- 4.3 -	- 5.3 (H); 5.7 (L) ⁶⁾
12.5	12.9	13.2	13.9	14.2	13.7	13.7	16.6 (H); 17.8 (L) ⁶⁾
285.0	330.0	369.0	395.0	383.0	387.0	378.9	374.8
- 47.5 -	- 54.1 -	- 59.5 -	- 61.7 -	- 59.8 -	- 58.6 -	- 57.4 -	- 58.6

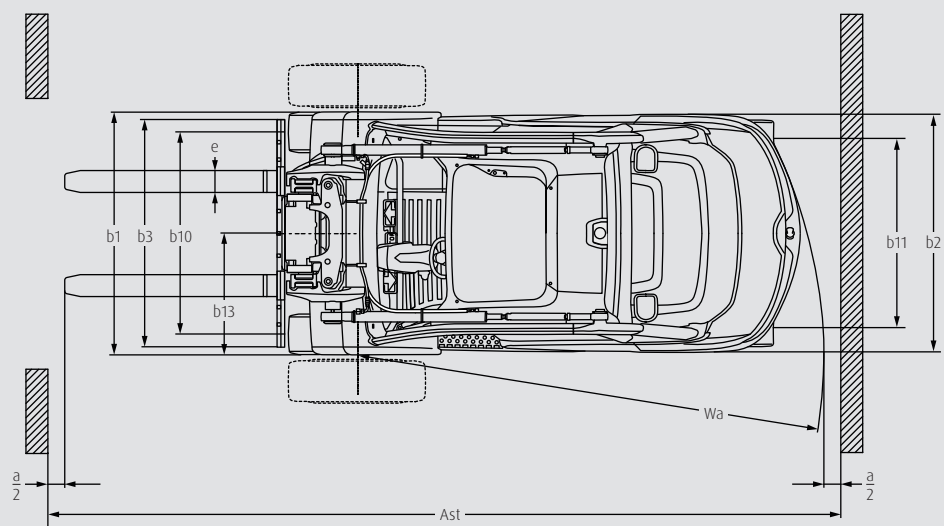
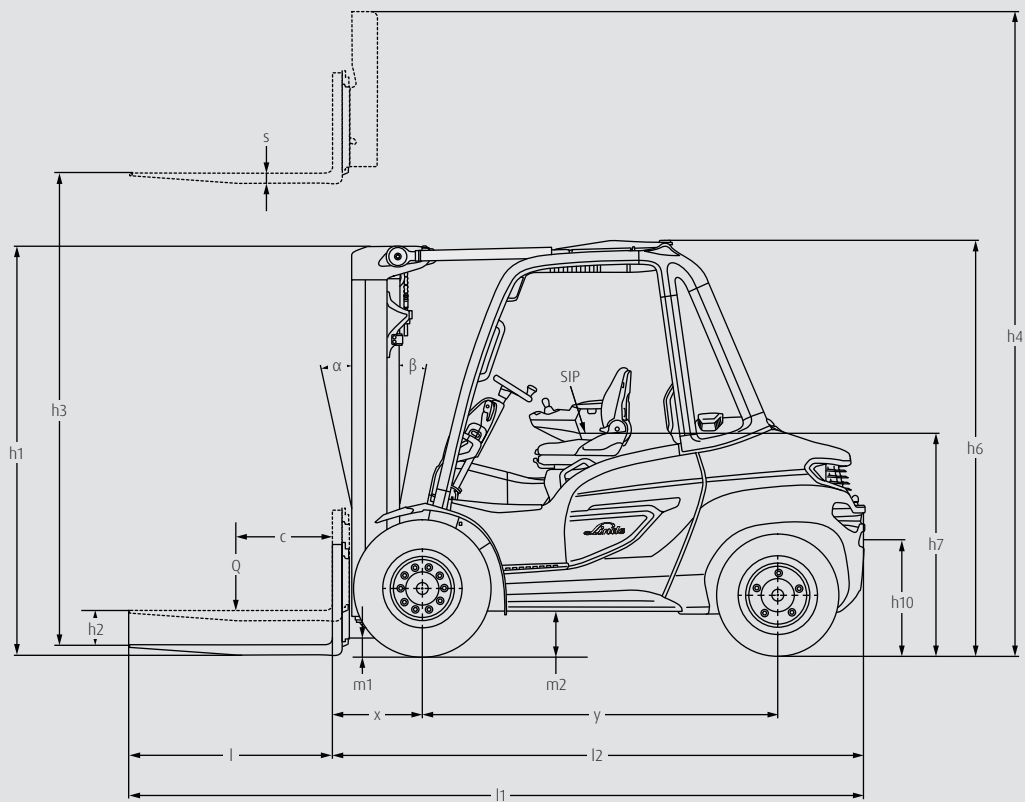

MAST TABLES

STANDARD MAST (in mm)

Series	1534						
Lift	h3: 2700 ¹⁾	h3: 3100	h3: 3200	h3: 3700	h3: 4100	h3: 4400	h3: 5000
Height measurements	h1: 2210 h2: 150 h4: 3605	h1: 2430 h2: 150 h4: 4020	h1: 2480 h2: 150 h4: 4120	h1: 2730 h2: 150 h4: 4620	h1: 2930 h2: 150 h4: 5020	h1: 3080 h2: 150 h4: 5320	h1: 3380 h2: 150 h4: 5920
Model							
H35/600	○	○	○	○	○	○	○
H40/600	○	○	○	○	○	○	○

Series	1534						
Lift	h3: 2700 ¹⁾	h3: 3100	h3: 3200	h3: 3700	h3: 4100	h3: 4400	h3: 5000
Height measurements	h1: 2210 h2: 150 h4: 3605	h1: 2480 h2: 150 h4: 4025	h1: 2530 h2: 150 h4: 4125	h1: 2780 h2: 150 h4: 4625	h1: 2980 h2: 150 h4: 5025	h1: 3130 h2: 150 h4: 5325	h1: 3430 h2: 150 h4: 5925
Model							
H45/600	○	○	○	○	○	○	○

Series	1534						
Lift	h3: 2500 ¹⁾	h3: 2900	h3: 3200	h3: 3700	h3: 4100	h3: 4400	h3: 5000
Height measurements	h1: 2210 h2: 150 h4: 3505	h1: 2480 h2: 150 h4: 3920	h1: 2630 h2: 150 h4: 4220	h1: 2880 h2: 150 h4: 4720	h1: 3080 h2: 150 h4: 5120	h1: 3230 h2: 150 h4: 5420	h1: 3530 h2: 150 h4: 6020
Model							
H50/500	○	○	○	○	○	○	○
H50/600	○	○	○	○	○	○	○
H50/600 Beverage	—	—	—	—	○	○	—

DUPLEX MAST (in mm)

Series	1534		
Lift	h3: 2730 ¹⁾	h3: 3130	h3: 3730
Height measurements	h1: 2170 h2: 1225 h4: 3665	h1: 2380 h2: 1425 h4: 4080	h1: 2680 h2: 1725 h4: 4680
Model			
H35/600	○	○	○
H40/600	○	○	○

Series	1534		
Lift	h3: 2730 ¹⁾	h3: 3130	h3: 3730
Height measurements	h1: 2170 h2: 1225 h4: 3665	h1: 2430 h2: 1475 h4: 4085	h1: 2730 h2: 1775 h4: 4685
Model			
H45/600	○	○	○

Series	1534	
Lift	h3: 2530 ¹⁾	h3: 2930
Height measurements	h1: 2170 h2: 1125 h4: 3565	h1: 2430 h2: 1375 h4: 3980
Model		
H50/500	○	○
H50/600	○	○
H50/600 Beverage	—	—

TRIPLEX MAST (in mm)

Series	1534			
Lift	h3: 4075 ¹⁾	h3: 4675	h3: 5365	h3: 6315
Height measurements	h1: 2170 h2: 122 h4: 5010	h1: 2380 h2: 142 h4: 5625	h1: 2630 h2: 167 h4: 6315	h1: 2980 h2: 202 h4: 7265
Model				
H35/600	○	○	○	○
H40/600	○	○	○	○

Series	1534			
Lift	h3: 4075 ¹⁾	h3: 4675	h3: 5365	h3: 6315
Height measurements	h1: 2170 h2: 122 h4: 5010	h1: 2430 h2: 147 h4: 5630	h1: 2680 h2: 172 h4: 6320	h1: 3030 h2: 207 h4: 7270
Model				
H45/600	○	○	○	○

Series	1534				
Lift	h3: 3775 ¹⁾	h3: 4375	h3: 4615	h3: 5565	h3: 6015
Height measurements	h1: 2170 h2: 112 h4: 4810	h1: 2430 h2: 137 h4: 5425	h1: 2530 h2: 147 h4: 5665	h1: 2880 h2: 182 h4: 6615	h1: 3030 h2: 197 h4: 7065
Model					
H50/500	○	○	○	○	○
H50/600	○	○	○	○	○
H50/600 Beverage	—	—	—	○	○

1) Container Version ○ Optional equipment — Not available

h1: Height of mast, lowered

h2: Free lift

h3: Lift

h4: Height of mast, extended

CHARACTERISTICS



All-round visibility

Safety

- Optimized design provides excellent visibility in all directions
- Roof with narrow crossbars and optional bulletproof glass simplifies work at high lift heights
- Low load center of the vehicle and a high mounted steering axle improve stability in curves
- Linde Curve Assist and Linde Load Assist reduce the risk of tipping and accidents during loading



Driver workplace

Ergonomics

- Ergonomic and intuitive operating concept maximizes forklift operator comfort
- Components decoupled from chassis (axles, mast and tilt cylinder) protect against shock and vibration
- Wide range of ergonomic seats prevent posture problems
- 3.5-inch display shows steering and tilt angles as standard and provides an overview of all important information at all times



Linde Load Control

Handling

- Linde Load Control and dual pedal control guarantee precise control of all travel and mast movements
- Top-mounted tilt cylinders guarantee torsional rigidity and high residual capacity at high lift heights
- Minimized fuel consumption reduces operating costs
- Freely programmable buttons in the armrest ensure access to frequently used functions



Easy service access

Service

- Robust design with low-wear and maintenance-free components ensures high vehicle availability
- Linde Engine Protection System (LEPS) provides additional protection against engine damage
- Extra-large service openings facilitate maintenance
- Standardized bolted connections save considerable time during maintenance and repairs

Subject to modification in the interest of progress. Illustrations and technical details could include options and not binding for actual constructions. All dimensions subject to usual tolerances.